

# Aria Pro 2

## User Manual



**Avantalk**

Model No.: ATBH-AS90P



# Contents

EN	User Manual	2
DE	Benutzerhandbuch	17
FR	Guide d'utilisation	34
IT	Manuale Utente	47
ES	Manual de Usuario	62

# Table of Contents

Box Contents .....	3
Product Introduction .....	4
Product Overview .....	4
Button Functions .....	5
LED Indicators .....	6
Charging the Headphones .....	7
Connecting the Headphones to Your Device .....	8
Pairing & Connecting .....	8
Configuring Audio Settings (only for PC) .....	10
Calling with the Boom Mic .....	12
Specifications .....	13
FAQ .....	14
Contact Us .....	16

# Box Contents

EN

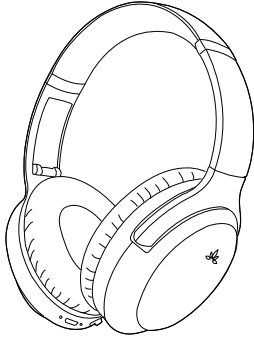

Aria Pro 2  
Headphones

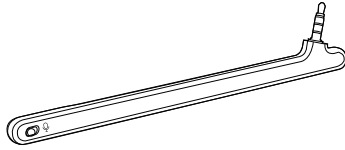

Boom Mic

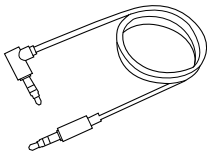

AUX 3.5mm  
Audio Cable

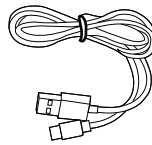





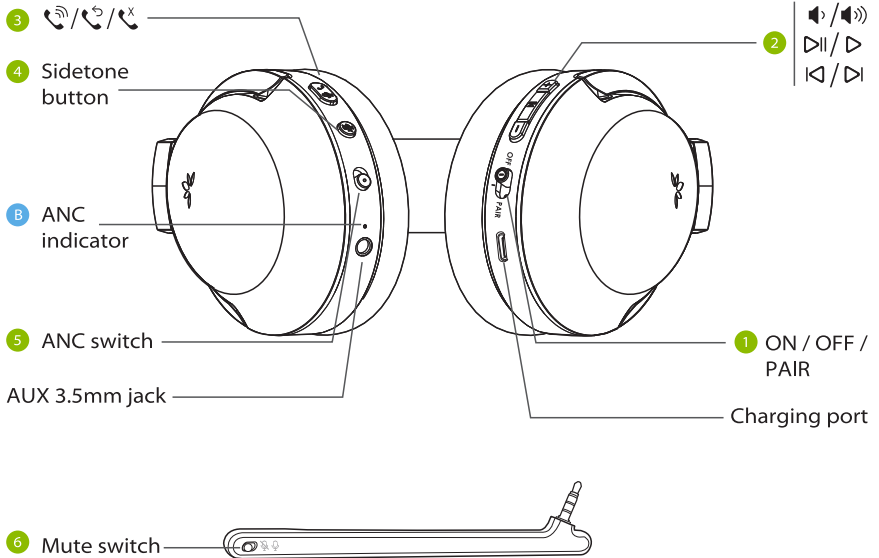

Type C Charging Cable

# Product Introduction

## Product Overview



## Button Functions

No.	Button	Functions
1		Switch to the "ON / OFF" position to turn the headphones on / off
		Switch to the "PAIR" position & hold for 3 seconds to enter pairing mode
2		Press once to play / pause
		Press once to increase / decrease volume
		Press & hold for 2 seconds to skip / replay track
		Press & hold both buttons for 5 seconds to clear pairing history
3		Press once to accept / end call
		Press & hold for 2 seconds to reject call
		Press twice to redial last number
4	Sidetone	During a call, press & hold for 3 seconds to turn sidetone on / off (aka mic monitoring - hear yourself speak)
5	ANC	Switch to turn the Active Noise Cancellation on / off.
6		Switch to  /  to unmute / mute microphone
2 4	Sidetone and 	Press & hold "Sidetone & +" or "Sidetone & -" for 1 second to turn voice prompt on / off

## LED Indicators

No.	Indicator & Voice Prompt	Status
A	Solid red	Charging
	Flashing red, "LOW BATTERY" voice indicator	Low battery
	Blue flash every 2 seconds, "WELCOME TO AVANTALK" voice indicator	Power on
	Solid red for 1 second then off, "GOODBYE" voice indicator	Power off
	Alternate red & blue flashes, "PAIRING" voice indicator	Pairing
	Blue flash every 5 seconds, "CONNECTED" voice indicator	Connected
	Blue flash every 2 seconds, "DISCONNECTED" voice indicator	Disconnected
	Solid pink for 5 seconds, then alternate red & blue flashes	Clearing pairing history
	Solid white for 5 seconds, two beeps	Sidetone on / off
B	Solid green, "NOISE CANCELING" voice indicator	Active Noise Cancellation (ANC) mode



## Charging the Headphones

A “LOW BATTERY” voice prompt and a flashing red **A** light will indicate low battery. In order to charge, you can use either a 5V/500mA-2A rated USB adapter (your phone charger or similar should work) or PC USB port as a power source.

Plug the provided type C power cable directly into the headphones' charging port.

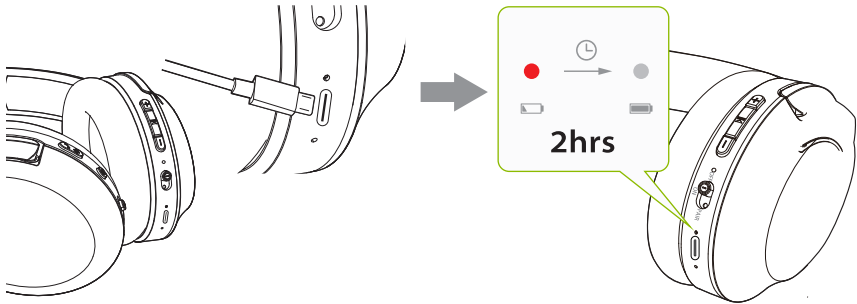

A solid red light indicates that charging is in progress; once the light turns off, your headphones will be at full battery.

# Connecting the Headphones to Your Device

## Pairing & Connecting

### STEP 1

Turn on the headphones and put them into PAIRING mode by sliding the  switch to "PAIR" and holding for 3 seconds or until the LED flashes red & blue.

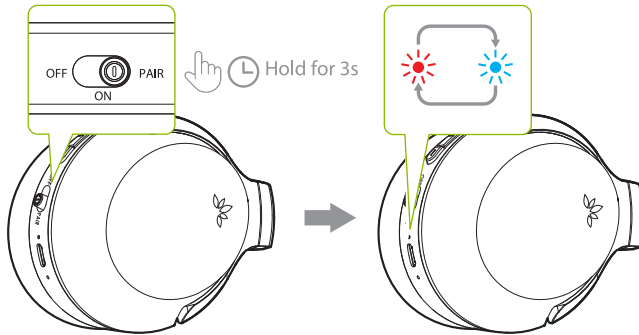



### STEP 2

Turn on your device's Bluetooth and select "Avantalk Aria Pro 2" in the Bluetooth menu.

**STEP 3**

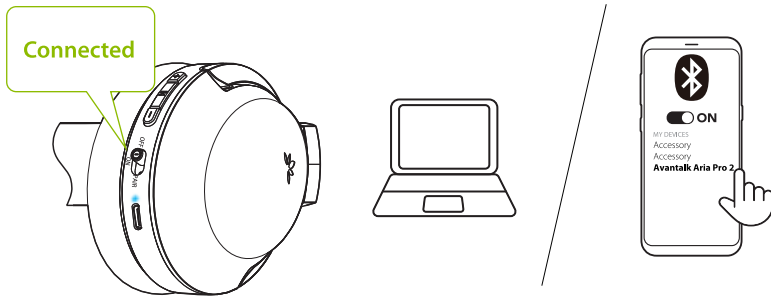
Keep the headphones close to your device and wait for 5-10 seconds or until they connect. Once they're successfully connected, you'll hear a "CONNECTED" voice indicator on headphones. The headphones' LED indicator will flash blue, then turn solid blue once you play audio.



For subsequent use, your headphones should automatically reconnect to the last-paired device within a few seconds of being turned on. If not, you can manually activate reconnection by sliding the **OFF**  **PAIR** switch to "PAIR" once, or by selecting "Avantalk Aria Pro 2" in your device's Bluetooth menu.

## Configuring Audio Settings (only for PC)

You may need to configure your audio settings when using the Aria Pro 2 with your PC or laptop.

### STEP 1

Access your device's audio settings and set "Avantalk Aria Pro 2" as the default in SOUND OUTPUT / PLAYBACK. Set "Avantalk Aria Pro 2" as the default in INPUT / MICROPHONE DEVICE.

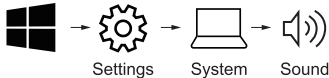

### Sound

**Output**  
Choose your output device

Avantalk Aria Pro 2 ▾

**Input**  
Choose your input device

Avantalk Aria Pro 2 ▾

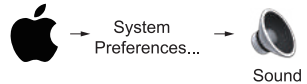

### Sound

**Output**  
Select a device for sound output:

Avantalk Aria Pro 2 ▾

**Input**  
Select a device for sound input:

Avantalk Aria Pro 2 ▾

**STEP 2**

Repeat the above steps in your meeting software (i.e. Teams, Zoom, Skype, etc.)

**Microsoft Teams**

Activity → Settings → Devices

**Audio devices**  
Avantalk Aria Pro2

**Speaker**  
Avantalk Aria Pro2 (Hands Free)

**Microphone**  
Avantalk Aria Pro2 (Hands Free)

**Zoom**

Settings → Audio

**Speaker** Test Speaker Avantalk Aria Pro2 (Hands Free)

**Microphone** Test Mic Avantalk Aria Pro2 (Hands Free)

**Discord**

Settings → VOICE SETTINGS

INPUT DEVICE: Avantalk Aria Pro2 (Hands Free)

OUTPUT DEVICE: Avantalk Aria Pro2 (Hands Free)

INPUT VOLUME: [Slider]

OUTPUT VOLUME: [Slider]

*NOTE: On Windows 11 / macOS, there is no "Hands Free" option; select "Avantalk Aria Pro 2" as the default instead.*

## Calling with the Boom Mic

The Aria Pro 2 headphones themselves have a built-in mic, but using the detachable boom mic will significantly enhance your call quality. Its noise-filtering technology will ensure your voice (and only your voice) is heard loud and clear, and its mute switch can be conveniently utilized.

# Specifications

## Headphones

EN

Bluetooth version	v5.0
Supported audio codecs	aptX-HD, aptX-LL, aptX, SBC
Supported profiles	HSP v1.2, HFP v1.7, AVRCP v1.6, A2DP v1.3.1
Operating range	Up to 30ft / 10m
Drivers	40mm
Impedance	32Ω
Frequency response	20Hz - 20KHz
Charging time	~2hrs
Operating time	Up to 24hrs (ANC off)
Standby time	325hrs (ANC off)
Product size	190mm x 175mm x 80mm
Headphones weight	~230g
Earpads inner diameter / depth	60mm x 40mm x 35mm
Earpads outer diameter	101mm x 80mm
Rated input	DC5V/500mA~2.0A
Power port	Type C

## FAQ

Below are some of the most common questions people have during setup.

### **Why is the microphone not working with my PC?**

There are several reasons why the microphone may not be working with your PC. First and foremost, check the boom mic to ensure the mute switch is OFF (unmuted). The issue could also be related to hardware or computer settings. To determine if it's a hardware issue, connect the headphones to your phone and test call someone, trying both with and without the boom mic. If there are no issues, double check your computer settings.

- Make sure only one meeting app is open at a time.
- Ensure your PC settings are properly set - check your computer's sound settings and make sure the Aria Pro 2 is selected as both the output and input source. Check your meeting software's sound settings as well.
- Make sure there's no interference from a second device - if your Aria Pro 2 is simultaneously connected to another device via dual link, try disconnecting from the other device.

### **I hear my mic transmitting ambient sounds when I'm in a call; why is that and do the people on the other side of the call hear that as well?**

If you have the sidetone feature active (which allows you to hear your own voice, aka mic monitoring), it will sometimes pick up surrounding noise on your end and you'll hear it in playback. Others in your call will NOT hear this if you're using the noise-filtering mic. You can try moving the boom mic closer to your mouth in order to reduce the amount of ambient noise transmitted through your sidetone, or you can turn sidetone off by pressing and holding the "sidetone" button for 3 seconds during a call if you prefer.



## **The indicator light on my headphones suddenly turned red and now the buttons don't work. What should I do?**

You can soft reset your headphones by plugging the charging cable into the headphones' charging port and plugging the other end into a power source for 3-5 seconds. This should reactivate the headphones' system and resolve the issue. If not, you can reach out to us at [support@avantalk.com](mailto:support@avantalk.com) and we can assist you directly!

You can find a full FAQ list at [avantree.com/support/aria-pro-2](https://avantree.com/support/aria-pro-2), or contact us directly for additional assistance.

## Contact Us

**Support Tickets**[avantree.com/submit-a-ticket](https://avantree.com/submit-a-ticket)**Support Email**[support@avantalk.com](mailto:support@avantalk.com)**USA / CA**

+1800 232 2078 (9am-6pm PST, Mon-Fri )

**UK**

+44 20 8068 2023 (9am-6pm, GMT, Mon-Sat)

**DE**

+49 32221097297 (11am-9pm, CET, Mon-Sat )

**FR**

+ 33 176340312 (11am-9pm, CET, Mon-Sat )

**IT**

+39 06 9480 3330 (9am-6pm, CET, Mon-Sat )

**ES**

+ 34 931786261 (9am-6pm, CET, Mon-Sat )

**AU**

+ 61 2 8310 9897 (11am-7pm, AEST, Mon-Fri)

**FAQ**[avantree.com/support/aria-pro-2](https://avantree.com/support/aria-pro-2)**Product Registration**[avantree.com/product-registration](https://avantree.com/product-registration)

# Inhaltsverzeichnis

Verpackungsinhalt .....	18
Produkteinführung .....	19
Produktübersicht .....	19
Testenfunktionen .....	20
LED Anzeige .....	21
Aufladen der Kopfhörer .....	22
Anschließen des Kopfhörers an Ihr Gerät .....	23
Koppeln und Verbinden .....	23
Konfigurierung der Audioeinstellungen (nur für PC) .....	25
Anrufen mit dem Boom Mic .....	27
Technische Angaben .....	28
FAQ .....	29
Kontakt .....	31

# Verpackungsinhalt

DE

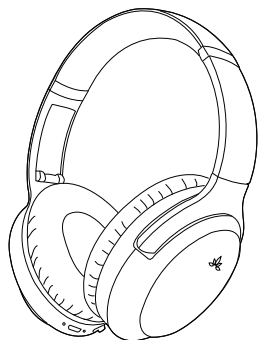

Aria Pro 2  
Kopfhörer

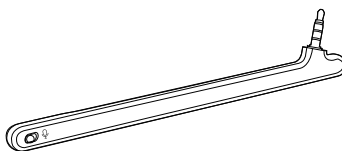

Boom Mic

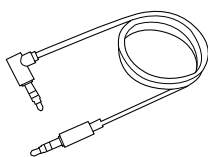

AUX-Audiokabel  
3,5 mm

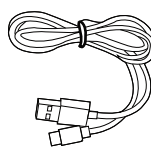

Typ C Ladekabel

# Produkteinführung





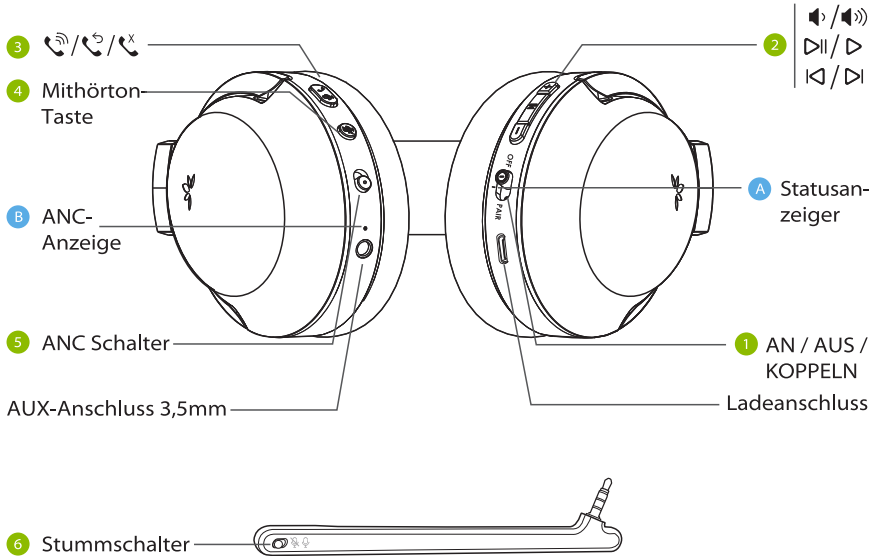



## Produktüberblick

DE



## Tastenfunktionen

DE

Nr.	Taste	Funktionen
1		Schalter auf "ON / OFF" stellen, um den Kopfhörer ein-/auszuschalten
		Schalter auf "PAIR" stellen und 3 Sekunden lang gedrückt halten, um die Kopplung zu aktivieren
2	 	Einmal drücken zum Abspielen/Pausieren
		Einmal drücken, um die Lautstärke zu erhöhen / verringern
		Taste 2 Sekunden lang gedrückt halten, um den Titel zu überspringen / wiederzugeben
3		Einmal drücken, um den Anruf anzunehmen/zu beenden
		2 Sekunden lang gedrückt halten, um den Anruf abzuweisen
		Zweimal drücken, um die letzte Nummer erneut zu wählen
4	Sidetone	Während eines Anrufs 3 Sekunden lang gedrückt halten, um den Mithörton ein- bzw. auszuschalten (auch Mikrofonüberwachung genannt - Sie hören sich selbst sprechen)
5	ANC	Schalter zum Ein- und Ausschalten der aktiven Geräuschunterdrückung
6		Auf  /  stellen, um den Stummmodus des Mikrofons ein-/auszuschalten
2 4	Sidetone and 	"Sidetone & +" oder "Sidetone & -" 1 Sekunde lang gedrückt halten, um die Sprachansage ein-/auszuschalten

## LED Anzeige

Nr.	Anzeige & Sprachansage	Status
A	Leuchtet rot	Im Ladezustand
	Blinkt rot, Sprachansage "LOW BATTERY"	Niedriger Akkustand
	Blinkt blau in 2-Sekundentakt, Sprachansage "WELCOME TO AVANTALK"	Betriebsbereit
	Leuchtet 1 Sekunde lang rot und geht aus, Sprachansage "GOODBYE"	Ausgeschaltet
	Blinkt abwechselnd rot & blau, Sprachansage "PAIRING"	Kopplung
	Blinkt blau in 5-Sekundentakt, Sprachansage "CONNECTED"	Verbunden
	Blinkt blau in 2-Sekundentakt, Sprachansage "DISCONNECTED"	Getrennt
	Leuchtet rosa 5 Sekunden lang, danach blinkt abwechselnd rot & blau	Löschen des Kopplungsverlaufs
	Leuchtet 5 Sekunden lang weiß, zwei Signaltöne	Mithören an / aus
B	Leuchtet grün, Sprachansage "NOISE CANCELING"	Aktive Geräuschunterdrückung (ANC)

## Aufladen der Kopfhörer

DE

A "LOW BATTERY" Sprachansage und rotes Blinken **A** Das Licht zeigt einen niedrigen Akkustand. Zum Aufladen können Sie entweder einen USB mit 5V/ 500mA-2A Adapter (Ihr Handy-Ladegerät oder ähnliches sollte funktionieren) oder den USB-Anschluss des PCs als Stromquelle verwenden. Stecken Sie das mitgelieferte Typ-C-Netzkabel direkt in den Ladeanschluss des Kopfhörers.

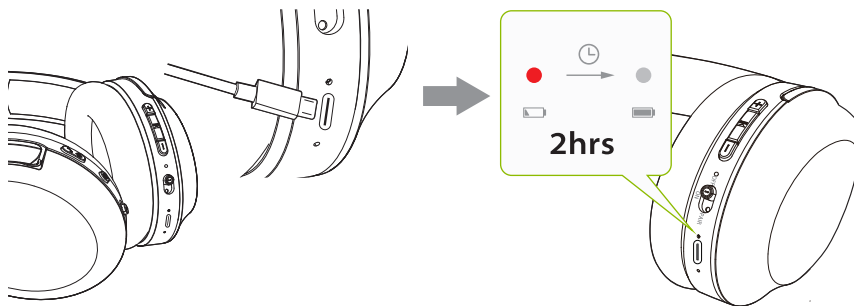

Ein durchgehendes rotes Leuchten zeigt an, dass der Ladevorgang läuft; sobald das Licht erlischt, ist der Akku Ihres Kopfhörers vollständig aufgeladen.



# Anschließen des Kopfhörers an Ihr Gerät

## Koppeln und Verbinden

DE

### SCHRITT 1

Schalten Sie die Kopfhörer ein und versetze sie in den PAIRING-Modus, indem Sie den Schalter **OFF**  **PAIR** auf "PAIR" schieben und ihn für 3 Sekunden oder bis die LED rot und blau blinkt, gedrückt halten.

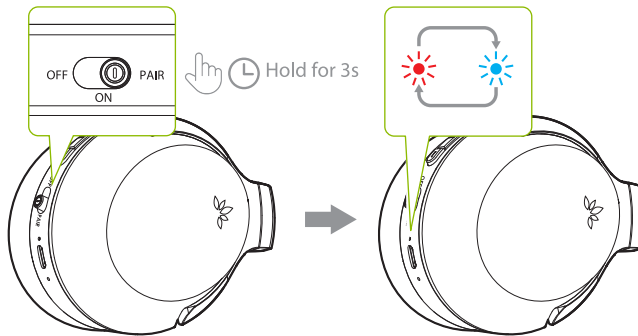



### SCHRITT 2

Schalten Sie das Bluetooth Ihres Geräts ein und wählen Sie "Avantalk Aria Pro 2" im Bluetooth-Menü.

### SCHRITT 3

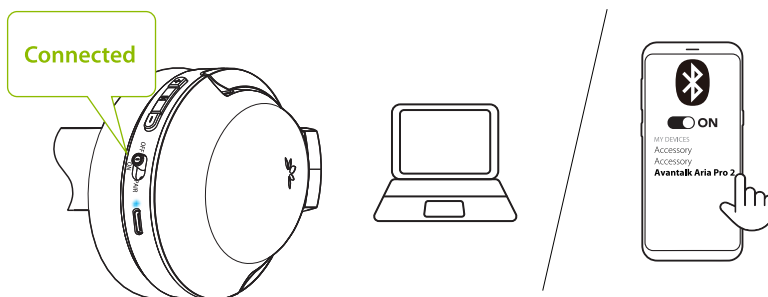
Um die Kopfhörer zu verbinden, halten Sie sie in der Nähe Ihres Geräts und warten Sie 5-10 Sekunden oder bis sie erfolgreich verbunden sind. Sobald die Verbindung hergestellt wurde, hören Sie eine Sprachanzeige am Kopfhörer, die "VERBINET" sagt. Die LED-Anzeige des Kopfhörers blinkt anfangs blau und leuchtet dann durchgehend blau, sobald Sie Audio abspielen.



Bei späterer Verwendung wird Ihr Kopfhörer sich in der Regel innerhalb weniger Sekunden nach dem Einschalten automatisch mit dem zuletzt gepaarten Gerät verbinden. Sollte dies nicht der Fall sein, können Sie die Wiederverbindung manuell aktivieren, indem Sie den Schalter **OFF**  **PAIR** einmal auf "PAIR" schieben oder im Bluetooth-Menü Ihres Geräts "Avantalk Aria Pro 2" auswählen.

## Konfigurierung der Audioeinstellungen (nur für PC)

Möglicherweise müssen Sie Ihre Audioeinstellungen konfigurieren, wenn Sie den Aria Pro 2 mit Ihrem PC oder Laptop verwenden.

DE

### SCHRITT 1

Greifen Sie auf die Audioeinstellungen Ihres Geräts zu und stellen Sie "Avantalk Aria Pro 2" als Standard in TONAUSGANG / WIEDERGABE ein. Stellen Sie "Avantalk Aria Pro 2" als Standard unter EINGANG / MIKROFONGERÄT ein.

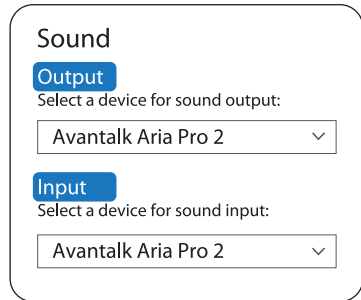
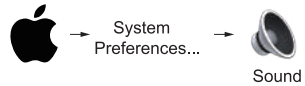
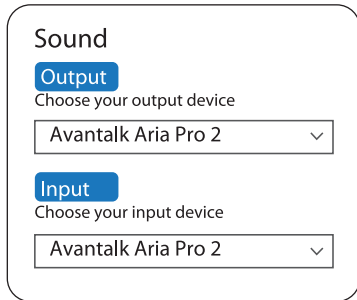
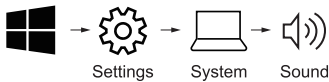

## SCHRITT 2

Wiederholen Sie die oben genannten Schritte in Ihrer Meeting-Software (z. B. Teams, Zoom, Skype usw.)

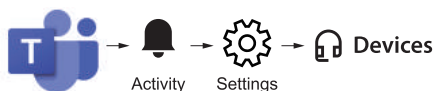

**Audio devices**

Avantalk Aria Pro2 ▾

**Speaker**

Avantalk Aria Pro2 (Hands Free) ▾

**Microphone**

Avantalk Aria Pro2 (Hands Free) ▾



**Speaker**  Avantalk Aria Pro2 (Hands Free) ⌵

**Microphone**  Avantalk Aria Pro2 (Hands Free) ⌵



**VOICE SETTINGS**

INPUT DEVICE: Avantalk Aria Pro2 (Hands Free) ▾

OUTPUT DEVICE: Avantalk Aria Pro2 (Hands Free) ▾

INPUT VOLUME:

OUTPUT VOLUME:

*HINWEIS: Unter Windows 11/macOS gibt es keine Option "Freisprecheinrichtung". Wählen Sie stattdessen "Avantalk Aria Pro 2" als Standard aus.*

## Anrufen mit dem Boom Mic

Obwohl die Aria Pro 2-Kopfhörer ein integriertes Mikrofon haben, kann die Gesprächsqualität erheblich verbessert werden, indem man das abnehmbare Bügelmikrofon verwendet. Dank der Geräuschfilterungstechnologie wird Ihre Stimme klar und deutlich übertragen, ohne störende Hintergrundgeräusche. Der bequem platzierte Stummschalter ermöglicht es Ihnen außerdem, das Mikrofon problemlos stummzuschalten, wenn nötig.

# Technische Angaben

## Kopfhörer

DE

Bluetooth version	v5.0
Unterstützte Audiocodexs	aptX-HD, aptX-LL, aptX, SBC
Unterstützte Profile	HSP v1.2, HFP v1.7, AVRCP v1.6, A2DP v1.3.1
Reichweite	Up to 30ft / 10m
Treiber	40mm
Impedanz	32Ω
Frequenzbereich	20Hz - 20KHz
Aufladezeit	~2hrs
Betriebsdauer	Up to 24hrs (ANC off)
Standby-Zeit	325hrs (ANC off)
Abmessungen des Produkts	190mm x 175mm x 80mm
Gewicht der Kopfhörer	~230g
Innendurchmesser / Tiefe der Ohrpolster	60mm x 40mm x 35mm
Außendurchmesser der Ohrpolster	101mm x 80mm
Nenneingangsspannung	DC5V/500mA~2.0A
Netzanschluss	Type C

## FAQ

Nachfolgend finden Sie einige der am häufigsten gestellten Fragen während der Einrichtung.

DE

### **Warum funktioniert das Mikrofon nicht mit meinem PC?**

Es gibt verschiedene Gründe, warum das Mikrofon möglicherweise nicht mit Ihrem PC funktioniert. Zunächst sollten Sie überprüfen, ob der Stummschalter am Mikrofon ausgeschaltet (nicht stummgeschaltet) ist. Es ist auch möglich, dass das Problem mit der Hardware oder den Computereinstellungen zusammenhängt. Um festzustellen, ob es sich um ein Hardwareproblem handelt, können Sie die Kopfhörer an Ihr Telefon anschließen und einen Testanruf mit und ohne Mikrofon durchführen. Wenn dabei keine Probleme auftreten, sollten Sie Ihre Computereinstellungen überprüfen.

- Stellen Sie sicher, dass immer nur eine Videokonferenz-Anwendung gleichzeitig geöffnet ist.
- Stellen Sie sicher, dass Ihre PC-Einstellungen korrekt sind. Überprüfen Sie die Sound-Einstellungen Ihres Computers und stellen Sie sicher, dass die Aria Pro 2 als sowohl Audio-Ausgangs- als auch Audio-Eingangsquelle ausgewählt ist. Überprüfen Sie auch die Sound-Einstellungen Ihrer Videokonferenz-Software.
- Achten Sie darauf, dass es keine Störungen durch eine gleichzeitige Verbindung mit einem anderen Gerät über Dual Link gibt. Wenn Ihr Aria Pro 2 gleichzeitig mit einem anderen Gerät verbunden ist, versuchen Sie, die Verbindung zu diesem anderen Gerät zu trennen.

### **Es kann vorkommen, dass mein Mikrofon Umgebungsgeräusche während eines Anrufs überträgt. Warum ist das so und hören die Personen auf der anderen Seite des Anrufs diese Geräusche auch?**

Wenn Sie die Mithörfunktion aktiviert haben, bei der Sie Ihre eigene Stimme hören können (auch bekannt als Mikrofonüberwachung), können manchmal Umgebungsgeräusche auf Ihrer Seite aufgenommen werden, die Sie während der Wiedergabe hören können. Es ist wichtig zu beachten, dass andere Gesprächsteilnehmer diese Geräusche NICHT hören, wenn Sie das Mikrofon mit Geräuschfilterung verwenden. Um die Übertragung von Umgebungsgeräuschen zu reduzieren, können Sie versuchen, das Bügelmikrofon näher an Ihren Mund zu bringen oder den Mithörton während eines Anrufs ausschalten, indem Sie die Taste "Mithörton" für 3 Sekunden gedrückt halten, wenn Sie dies bevorzugen.

### **Die Anzeigelampe meines Kopfhörers leuchtete plötzlich rot auf, und jetzt funktionieren die Tasten nicht mehr. Was soll ich tun?**

Sie können einen Soft-Reset Ihres Kopfhörers durchführen, indem Sie das Ladekabel in den Ladeanschluss des Kopfhörers stecken und das andere Ende für 3-5 Sekunden an eine Stromquelle anschließen. Dadurch sollte das System des Kopfhörers reaktiviert und das Problem behoben werden. Wenn dies nicht der Fall ist, können Sie uns unter [support@avantalk.com](mailto:support@avantalk.com) kontaktieren und wir können Ihnen direkt helfen!

Eine vollständige FAQ-Liste finden Sie unter [avantree.com/support/aria-pro-2](https://avantree.com/support/aria-pro-2), oder kontaktieren Sie uns direkt, wenn Sie weitere Hilfe benötigen.



# Kontakt

**Support Tickets**[avantree.com/submit-a-ticket](https://avantree.com/submit-a-ticket)**Support Email**[support@avantalk.com](mailto:support@avantalk.com)**USA / CA**

+1800 232 2078 (9am-6pm PST, Mon-Fri )

**UK**

+44 20 8068 2023 (9am-6pm, GMT, Mon-Sat)

**DE**

+49 32221097297 (11am-9pm, CET, Mon-Sat )

**FR**

+ 33 176340312 (11am-9pm, CET, Mon-Sat )

**IT**

+39 06 9480 3330 (9am-6pm, CET, Mon-Sat )

**ES**

+ 34 931786261 (9am-6pm, CET, Mon-Sat )

**AU**

+ 61 2 8310 9897 (11am-7pm, AEST, Mon-Fri)

**FAQ**[avantree.com/support/aria-pro-2](https://avantree.com/support/aria-pro-2)**Product Registration**[avantree.com/product-registration](https://avantree.com/product-registration)

# Sommaire

Contenu de la boîte .....	33
Introduction .....	34
Vue d'ensemble .....	34
Fonction des boutons .....	35
Indicateurs LED .....	36
Charge du casque .....	37
Connexion du casque à votre appareil .....	38
Appairage & Connexion .....	38
Configurer les paramètres audio (Pour PC) .....	40
Appels avec le micro-perche .....	42
Specifications .....	43
FAQ .....	44
Contact Us .....	46

# Box Contents

FR

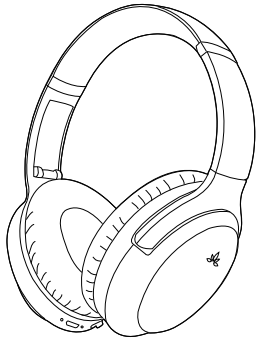

Casque  
Aria Pro 2

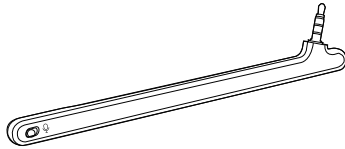

Micro-perche

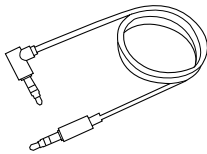

Câble audio  
UX 3.5mm

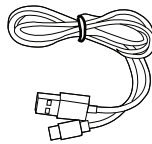

Câble de charge  
USB Type C







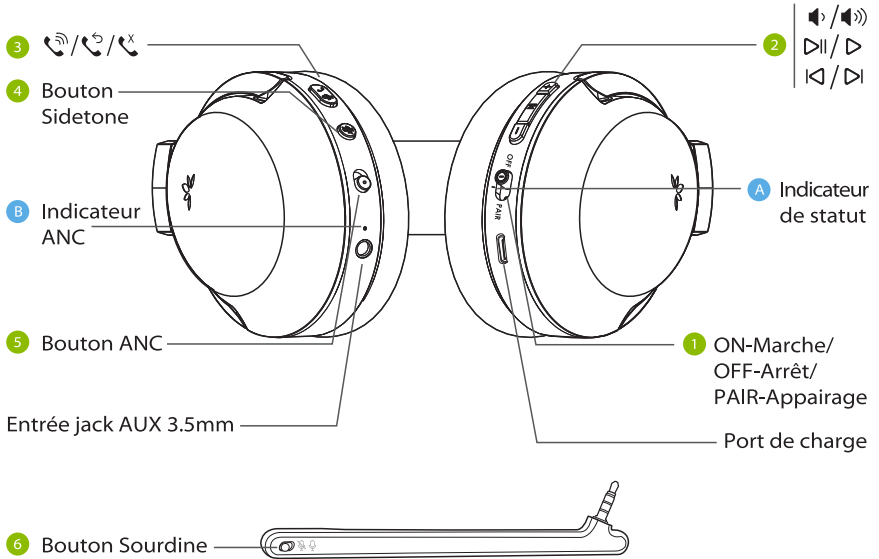

# Introduction

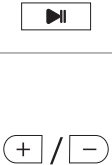
## Vue d'ensemble

FR



## Fonction des boutons

Nbr.	Bouton	Fonctions
1		Basculer sur "ON / OFF" pour éteindre ou allumer le casque.
		Basculer sur "PAIR" & maintenir 3 sec. pour passer en appairage
2		Appuyez 1x pour lire / mettre en pause la musique
		Appuyez 1x pour augmenter/baisser le volume
		Appuyez & maintenez enfoncé pendant 2 sec. pour sauter / rejouer la piste
3		Appuyez 1x pour accepter/clore l'appel
		Appuyez & maintenez 2 sec. pour rejeter l'appel
		Appuyez 2x pour recomposer le dernier numéro
4	Side-tone 	En appel, appuyez et maintenez enfoncé 3 sec. pour activer/désactiver l'effet Sidetone (vous entendrez votre voix)
5	ANC 	Bouton pour activer / désactiver la suppression active du bruit.
6		Basculez  /  activer / désactiver le micro
2 4	Side-tone  & 	Appuyez et maintenez le bouton Sidetone & "+" ou "-" pendant 1 sec. pour activer / désactiver l'invite vocale

## Indicateurs LED

Nbr.	Indicateur et invite vocale	Statut
A	Rouge fixe	En charge
	Rouge clignotant, vocalise "LOW BATTERY"	Batterie faible
	Bleu clignotant 2 secondes, vocalise "WELCOME TO AVANTALK"	Marche
	Rouge continu pendant 1 seconde puis éteint , vocalise "GOODBYE"	Arrêt
	Clignotements rouges et bleus alternés, vocalise "PAIRING"	Appairage
	Flash bleu toutes les 5 secondes, vocalise "CONNECTED"	Connecté
	Flash bleu toutes les 2 secondes, vocalise "DISCONNECTED"	Déconnecté
	Rose fixe pendant 5 secondes, puis clignotement alterné rouge et bleu	Effacement du jumelage
	Blanc fixe pendant 5 secondes, puis 2 bips	Sidetone éteint/allumé
B	Vert fixe, vocalise "NOISE CANCELING"	Réduction du bruit (ANC) activé

## Charge du casque

Une invite vocale « LOW BATTERY » et un voyant rouge clignotant **A** indiqueront une batterie faible. Pour recharger le casque, utilisez un adaptateur USB 5V/500mA-2A (ex. chargeur de téléphone ou similaire) ou un port USB PC comme source d'alimentation.

Branchez le câble d'alimentation USB C fourni dans le port de charge du casque.

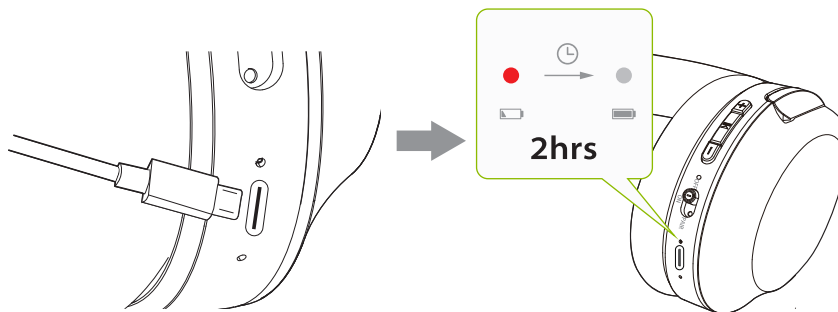

Un voyant rouge fixe indique que la charge est en cours ; une fois la lumière éteinte, vos écouteurs seront rechargés.

# Connexion du casque à votre appareil

## Appairage & Connexion

FR

### ETAPE 1

Allumez les écouteurs, mettez-les en APPAIRAGE en glissant sur "PAIR" et en le maintenant enfoncé 3 sec. jusqu'à la voir la LED rouge et bleu clignotante.

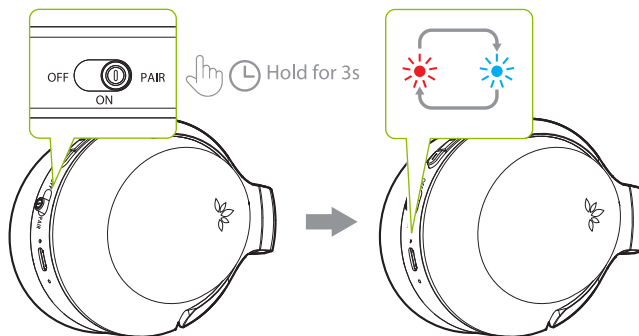

### ETAPE 2

Activez le Bluetooth de votre appareil et sélectionnez "Avantalk Aria Pro 2" dans le menu Bluetooth.



### ETAPE 3

Gardez les écouteurs près de votre appareil et attendez 5 à 10 secondes jusqu'à ce qu'ils se connectent. Une fois connectés, vous entendrez "CONNECTED" dans le casque. Son indicateur LED clignotera en bleu, puis deviendra bleu fixe une fois que vous jouerez un son.

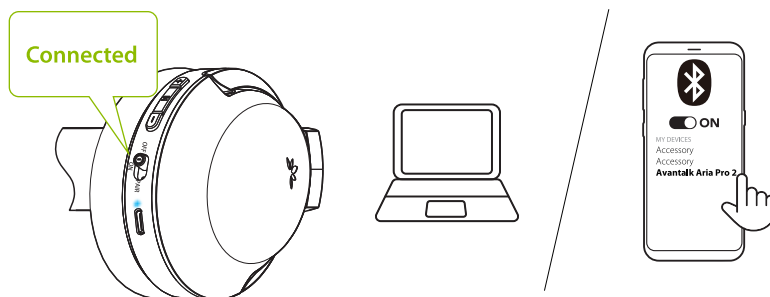

Ultérieurement, votre casque devrait se reconnecter automatiquement au dernier appareil couplé après sa mise sous tension. Sinon, activez manuellement la reconnexion en glissant  sur "PAIR" 1x, ou en sélectionnant "Avantalk Aria Pro 2" dans le menu Bluetooth de votre appareil.

## Configurer les paramètres audio (Sur PC)

Vous devrez peut-être configurer vos paramètres audio lorsque vous utilisez l'Aria Pro 2 avec votre PC ou un ordinateur portable.

FR

### ETAPE 1

Accédez aux paramètres audio de votre appareil et définissez "Avantalk Aria Pro 2" comme valeur par défaut dans SORTIE AUDIO / LECTURE. Définissez "Avantalk Aria Pro 2" comme valeur par défaut dans ENTREE AUDIO / MICRO.

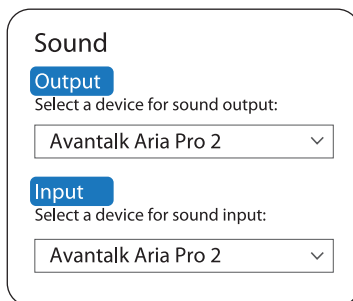
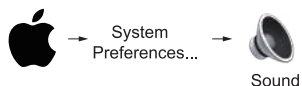
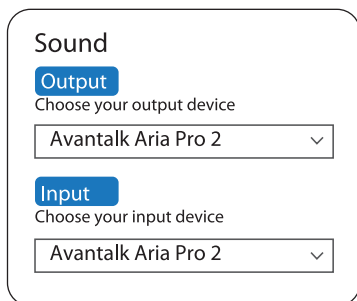
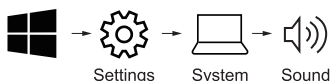

## ETAPE 2

Répétez les étapes ci-dessus pour votre logiciel tiers (i.e. Teams, Zoom, Skype, etc.)

**Audio devices**  
Avantalk Aria Pro2

**Speaker**  
Avantalk Aria Pro2 (Hands Free)

**Microphone**  
Avantalk Aria Pro2 (Hands Free)

**Speaker** Test Speaker Avantalk Aria Pro2 (Hands Free)

**Microphone** Test Mic Avantalk Aria Pro2 (Hands Free)

**VOICE SETTINGS**

INPUT DEVICE: Avantalk Aria Pro2 (Hands Free)

OUTPUT DEVICE: Avantalk Aria Pro2 (Hands Free)

INPUT VOLUME: [Slider]

OUTPUT VOLUME: [Slider]

*NOTE: Sur Windows 11/macOS, l'option "Hands Free" est absente. Sélectionnez "Avantalk Aria Pro 2" par défaut.*

## Appels avec le micro-perche

FR

Les écouteurs Aria Pro 2 disposent d'un micro intégré, mais l'utilisation du micro-perche amovible améliorera considérablement la qualité de vos appels. Sa technologie de filtrage du bruit garantira que votre voix (et uniquement votre voix) sera claire et forte, et son interrupteur sourdine peut être facilement utilisé.

# Spécifications

## Casque audio

Version Bluetooth	v5.0
Codecs audio supportés	aptX-HD, aptX-LL, aptX, SBC
Profils supportés	HSP v1.2, HFP v1.7, AVRCP v1.6, A2DP v1.3.1
Portée	Jusqu'à 10m
Haut-parleurs	40mm
Impédance	32Ω
Réponse en fréquence	20Hz - 20KHz
Temps de charge	~2h
Temps d'utilisation	Jusqu'à 24h (ANC éteint)
Veille	Jusqu'à 325h (ANC éteint)
Dimensions produit	190mm x 175mm x 80mm
Poids du casque	~230g
Diamètre intérieur / profondeur des coussinets	60mm x 40mm x 35mm
Diamètre extérieur des coussinets	101mm x 80mm
Tensions de charge	DC5V/500mA~2.0A
Port d'alimentation	Type C

## FAQ

Vous trouverez ci-dessous certaines des questions les plus fréquemment posées par les utilisateurs.

FR

### **Pourquoi le microphone ne fonctionne-t-il pas avec mon PC?**

Plusieurs raisons à cela. Tout d'abord, vérifiez que le bouton Sourdis sur le micro-perche est sur OFF (désactivé). Le problème peut également être lié au matériel ou aux paramètres de l'ordinateur. Pour déterminer s'il s'agit d'un problème matériel, connectez le casque à votre téléphone et essayez d'appeler quelqu'un, avec et sans le micro-perche. S'il n'y a aucun problème, vérifiez les paramètres de votre ordinateur.

- Assurez-vous qu'une seule application de réunion est ouverte à la fois.
- Assurez-vous que les paramètres de votre PC sont correctement définis - vérifiez les paramètres de son de votre ordinateur et assurez-vous que l'Aria Pro 2 est sélectionné comme source de sortie et aussi d'entrée. Vérifiez également les paramètres sonores de votre logiciel de réunion.
- Assurez-vous qu'il n'y a pas d'interférence provenant d'un deuxième appareil - si votre Aria Pro 2 est simultanément connecté à un autre appareil via une double liaison, essayez de vous déconnecter de l'autre appareil.

### **J'entends mon micro transmettre des sons ambiants en appel ; pourquoi mes interlocuteurs l'entendent aussi?**

Si la fonction Sidetone est active (écoute de votre propre voix), elle captera parfois le bruit environnant de votre côté et vous pourrez l'entendre. Vos interlocuteurs ne l'entendront PAS si vous utilisez le micro antibruit. Essayez aussi de rapprocher le micro-perche de votre bouche afin de réduire la quantité de bruit ambiant transmis par le Sidetone, ou désactivez le Sidetone en appuyant sur le bouton "Sidetone" et en le maintenant enfoncé pendant 3 secondes pendant un appel.

## **Le voyant lumineux de mon casque est soudainement devenu rouge et maintenant les boutons ne fonctionnent plus. Que faire?**

Vous pouvez réinitialiser votre casque en branchant le câble de charge dans le port de charge du casque et en branchant l'autre extrémité sur une source d'alimentation, pendant 3 à 5 secondes. Cela devrait réactiver le système du casque et résoudre le problème. Sinon, contactez-nous via [support@avantalk.com](mailto:support@avantalk.com) et nous vous assisterons !

Pour une liste complète des FAQ, consultez [avantree.com/support/aria-pro-2](https://avantree.com/support/aria-pro-2), ou contactez-nous directement pour une assistance supplémentaire.

## Contactez-nous

**Support Tickets**[avantree.com/submit-a-ticket](https://avantree.com/submit-a-ticket)**Support Email**[support@avantalk.com](mailto:support@avantalk.com)**USA / CA**

+1800 232 2078 (9am-6pm PST, Mon-Fri )

**UK**

+44 20 8068 2023 (9am-6pm, GMT, Mon-Sat)

**DE**

+49 32221097297 (11am-9pm, CET, Mon-Sat )

**FR**

+ 33 176340312 (11am-9pm, CET, Mon-Sat )

**IT**

+39 06 9480 3330 (9am-6pm, CET, Mon-Sat )

**ES**

+ 34 931786261 (9am-6pm, CET, Mon-Sat )

**AU**

+ 61 2 8310 9897 (11am-7pm, AEST, Mon-Fri)

**FAQ**[avantree.com/support/aria-pro-2](https://avantree.com/support/aria-pro-2)**Product Registration**[avantree.com/product-registration](https://avantree.com/product-registration)



# Indice dei Contenuti

Contenuto della Confezione .....	48
Introduzione al Prodotto .....	49
Panoramica del prodotto .....	49
Funzione dei Tasti .....	50
Indicatori LED .....	51
Ricaricare le Cuffie .....	52
Collegamento delle Cuffie al Dispositivo .....	52
Pairing & Connessione .....	53
Configurazione Impostazioni Audio (solo per PC) .....	55
Chiamare con il Microfono Esterno .....	57
Specifiche .....	58
FAQ .....	59
Contattaci .....	61



# Verpackungsinhalt

IT

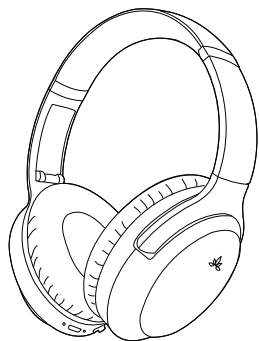

Cuffie Aria Pro 2

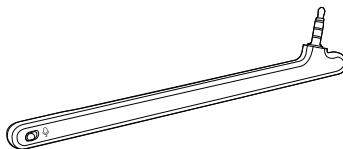

Microfono Esterno

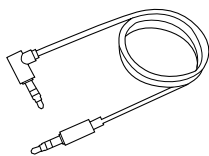

Cavo Audio  
AUX 3.5mm

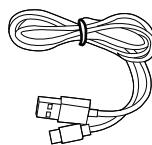







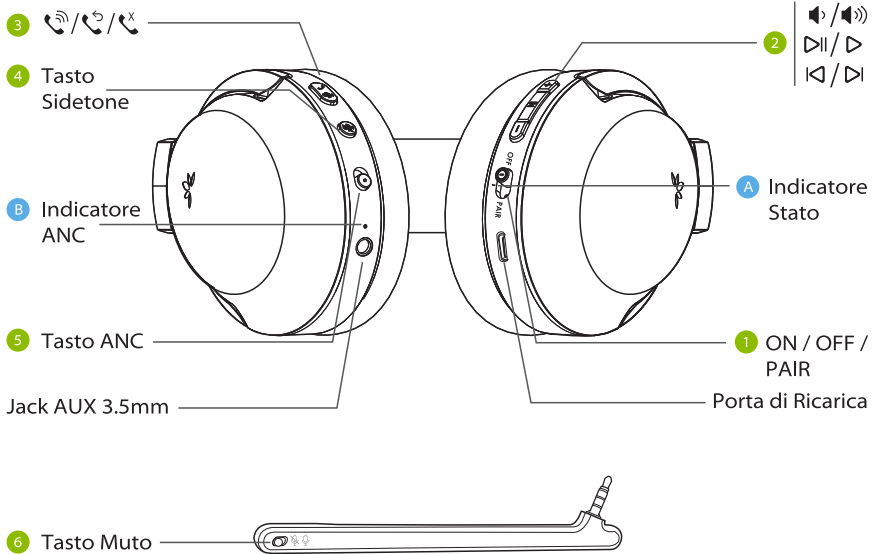



Cavo di Ricarica  
Type C

# Introduzione al Prodotto

## Panoramica del prodotto



## Funzione dei Tasti

No.	Tasto	Funzione
1		Passare alla posizione "ON/OFF" per accendere/spengere le cuffie
		Scorrere alla posizione "PAIR" e tenere premuto per 3 secondi per accedere alla modalità di associazione
2		Premere una volta per riprodurre/mettere in pausa
		Premere una volta per aumentare/diminuire il volume
		Tenere premuto per 2 secondi per saltare/riprodurre la canzone
3		Tenere premuto per 2 secondi per rifiutare la chiamata
		Premere due volte per ricomporre l'ultimo numero
		Premere una volta per accettare/terminare la chiamata
4	Side-tone 	Durante una chiamata, tenerlo premuto per 3 secondi per attivare/disattivare il sidetone (il monitoraggio del microfono)
5	ANC 	Scorrere per attivare/disattivare la cancellazione attiva del rumore
6		Scorrere su  /  per attivare/disattivare il microfono
2 4	Side-tone  & 	Tenere premuto "Sidetone & +" o "Sidetone & -" per 1 secondo per attivare/disattivare gli avvisi vocali

## Indicatori LED

No.	Indicatore e Avviso Vocale	Stato
A	Rosso fisso	Carica
	Rosso lampeggiante, avviso vocale "LOW BATTERY"	Batteria scarica
	Blu lampeggiante ogni 2 secondi, avviso vocale "WEL-COME TO AVANTALK"	Acceso
	Rosso fisso per 1 secondo poi spento, avviso vocale "GOOD-BYE"	Spento
	Lampeggi rossi e blu alternati, avviso vocale "PAIRING".	Pairing
	Lampeggio blu ogni 5 secondi, avviso vocale "CONNECTED".	Connesso
	Lampeggio blu ogni 2 secondi, avviso vocale "DISCONNECTED".	Disconnesso
	Rosa fisso per 5 secondi, quindi lampeggi rossi e blu alternati	Storico connessioni cancellato
	Bianco fisso per 5 secondi, due bip	Sidetone acceso / spento
B	Verde fisso, avviso vocale "NOISE CANCELING"	Modalità Cancellazione Attiva Rumore (ANC)

## Ricaricare le Cuffie

Un messaggio vocale "LOW BATTERY" e una spia rossa lampeggiante indicheranno che la batteria è scarica. Per caricare le cuffie, è possibile utilizzare come fonte di alimentazione un adattatore USB da 5V/500mA-2 A (il caricatore del telefono o uno simile dovrebbe funzionare) o la porta USB del PC.

Collega il cavo di alimentazione di tipo C incluso direttamente alla porta di ricarica delle cuffie.

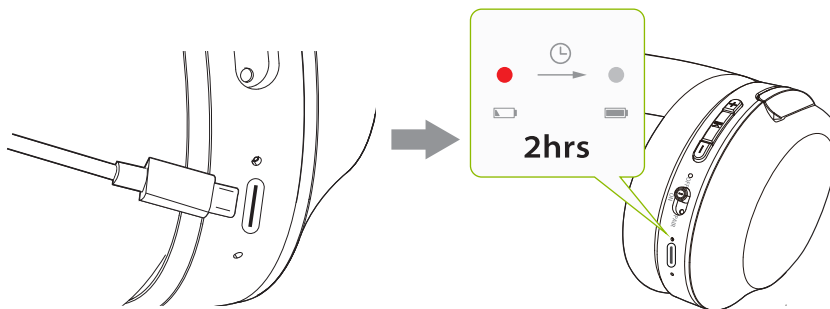

Una luce rossa fissa indica che la ricarica è in corso; una volta che la luce si spegne, le tue cuffie saranno completamente cariche.

# Collegamento delle Cuffie al Dispositivo

## Pairing & Connessione

### PASSO 1

Accendi le cuffie e mettile in modalità PAIRING facendo scorrere il tasto

OFF  PAIR su "PAIR" e tenendolo in posizione per 3 secondi o fino a quando il

LED lampeggia in rosso e blu.

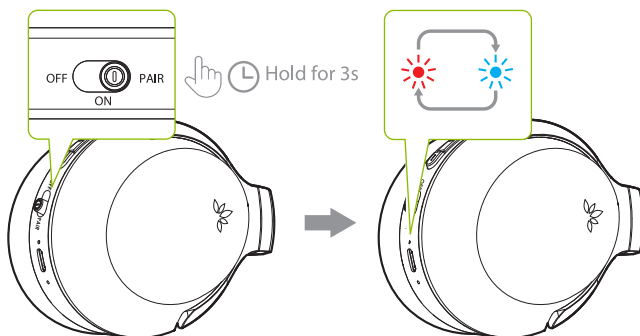

### PASSO 2

Attiva il Bluetooth del tuo dispositivo e seleziona "Avantalk Aria Pro 2" nel menu Bluetooth.

### PASSO 3

Mantieni le cuffie vicino al tuo dispositivo e attendi 5-10 secondi o finché non si connettono. Una volta collegati correttamente, sentirai un indicatore vocale "CONNECTED" sulle cuffie. L'indicatore LED delle cuffie lampeggerà in blu, quindi diventerà blu fisso una volta riprodotto l'audio.

IT

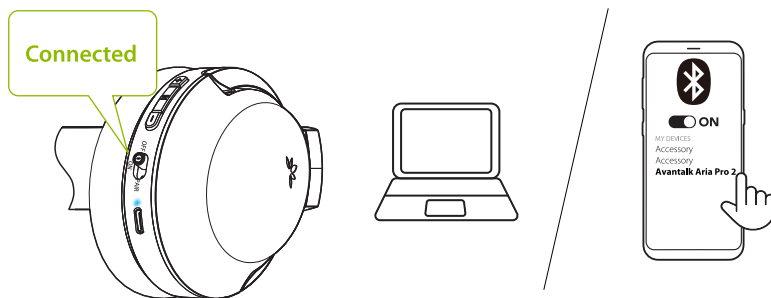

Per un utilizzo successivo, le cuffie dovrebbero riconnettersi automaticamente all'ultimo dispositivo associato entro pochi secondi dall'accensione. In caso contrario, è possibile attivare manualmente la riconnessione facendo scorrere il tasto **OFF**  **PAIR** su "PAIR" una volta, o selezionando "Avantalk Aria Pro 2" nel menu Bluetooth del tuo dispositivo.



## Configurazione Impostazioni Audio (solo per PC)

Potrebbe essere necessario configurare le impostazioni audio quando si utilizza Aria Pro 2 con il PC o il laptop.

### PASSO 1

Accedi alle impostazioni audio del tuo dispositivo e imposta "Avantalk Aria Pro 2" come predefinito in USCITA AUDIO / RIPRODUZIONE. Impostare "Avantalk Aria Pro 2" come predefinito in DISPOSITIVO INGRESSO/MICROFONO.

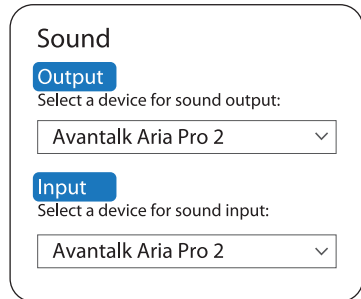
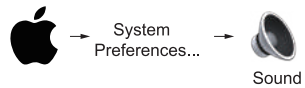
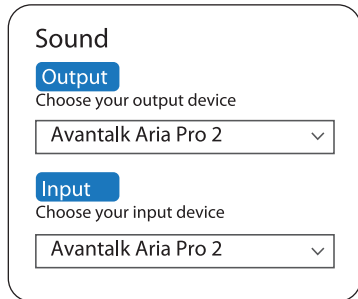
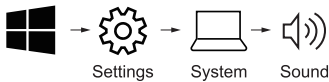

## PASSO 2

Ripeti i passi qua sopra nel tuo software per riunioni ( Teams, Zoom, Skype, etc.).

IT

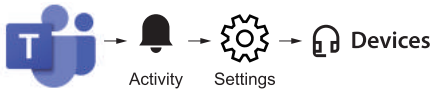

**Audio devices**

Avantalk Aria Pro2 ▾

**Speaker**

Avantalk Aria Pro2 (Hands Free) ▾

**Microphone**

Avantalk Aria Pro2 (Hands Free) ▾

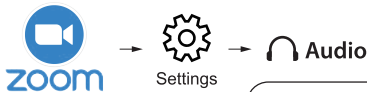

**Speaker**  Avantalk Aria Pro2 (Hands Free) ▾

**Microphone**  Avantalk Aria Pro2 (Hands Free) ▾



**VOICE SETTINGS**

INPUT DEVICE: Avantalk Aria Pro2 (Hands Free) ▾

OUTPUT DEVICE: Avantalk Aria Pro2 (Hands Free) ▾

INPUT VOLUME:

OUTPUT VOLUME:

*NOTA: Su Windows 11 / macOS, non è disponibile l'opzione "Vivavoce"; seleziona invece "Avantalk Aria Pro 2" come predefinito.*

## Chiamare con il Microfono Esterno

Le cuffie Aria Pro 2 hanno un microfono integrato, ma l'utilizzo del microfono esterno migliorerà in modo significativo la qualità della chiamata. La sua tecnologia di filtraggio del rumore assicurerà che la tua voce (e solo la tua voce) sia udita forte e chiara e il suo interruttore mute può essere utilizzato comodamente.



# Specifiche

## Cuffie

IT

Versione Bluetooth	v5.0
Codec audio supportati	aptX-HD, aptX-LL, aptX, SBC
Profili supportati	HSP v1.2, HFP v1.7, AVRCP v1.6, A2DP v1.3.1
Raggio di portata	Fino a 30ft / 10m
Drivers	40mm
Impedenza	32Ω
Frequenza di risposta	20Hz - 20KHz
Tempo di ricarica	~2 ore
Tempo di utilizzo	Fino a 24 ore (ANC spento)
Tempo di standby	325 ore (ANC spento)
Misure	190mm x 175mm x 80mm
Peso delle cuffie	~230g
Diametro interno cuffie	60mm x 40mm x 35mm
Diametro esterno cuffie	101mm x 80mm
Input	DC5V/500mA~2.0A
Porta di alimentazione	Type C

## FAQ

Di seguito sono riportate alcune delle domande più comuni che le persone hanno durante l'installazione del prodotto.

### **Perchè il microfono non funziona sul PC?**

Ci sono diversi motivi per cui il microfono potrebbe non funzionare con il PC. Prima di tutto, controlla il microfono esterno per assicurarti che l'interruttore di disattivazione dell'audio sia disattivato. Il problema potrebbe anche essere correlato all'hardware o alle impostazioni del computer. Per determinare se si tratta di un problema hardware, collega le cuffie al telefono e prova a chiamare qualcuno, provando sia con che senza il microfono ad asta. Se non ci sono problemi, ricontraolla le impostazioni del tuo computer.

- Assicurati che sia aperta una sola app per riunioni alla volta.
- Assicurati che le impostazioni del tuo PC siano corrette: controlla le impostazioni audio del computer e assicurati che Aria Pro 2 sia selezionato sia come dispositivo di uscita che di ingresso audio. Controlla anche le impostazioni audio del software per riunioni.
- Assicurati che non ci siano interferenze da un secondo dispositivo: se Aria Pro 2 è connesso contemporaneamente a un altro dispositivo tramite dual link, prova a disconnetterti dall'altro dispositivo.

## **Sento il microfono che trasmette suoni ambientali durante una chiamata; perché succede? Anche le persone dall'altra parte della chiamata lo sentono?**

IT

Se hai la funzione sidetone attiva (che ti consente di ascoltare la tua voce), a volte il rumore verrà rilevato circostante e potresti sentirlo durante la riproduzione. Gli altri partecipanti alla chiamata NON lo sentiranno se utilizzi il microfono con filtro del rumore. Puoi provare ad avvicinare il microfono esterno alla bocca per ridurre la quantità di rumore ambientale trasmesso attraverso il sidetone, oppure puoi disattivare il sidetone tenendo premuto il pulsante "sidetone" per 3 secondi durante una chiamata, se preferisci.

## **L'indicatore luminoso sulle mie cuffie è diventato improvvisamente rosso e ora i pulsanti non funzionano. Cosa dovrei fare?**

Puoi reimpostare le cuffie collegando il cavo di ricarica alla porta di ricarica delle cuffie e collegando l'altra estremità a una fonte di alimentazione per 3-5 secondi. Questo dovrebbe riattivare il sistema delle cuffie e risolvere il problema. In caso contrario, puoi contattarci all'indirizzo [support@avantalk.com](mailto:support@avantalk.com) e possiamo aiutarti direttamente!

Puoi trovare un elenco completo delle domande frequenti su [avantree.com/support/aria-pro-2](https://avantree.com/support/aria-pro-2) o contattaci direttamente per ulteriore assistenza.

## Contattaci

 **Support Tickets** [avantree.com/submit-a-ticket](https://avantree.com/submit-a-ticket)

---

 **Support Email** [support@avantalk.com](mailto:support@avantalk.com)

---

 **USA / CA** +1800 232 2078 (9am-6pm PST, Mon-Fri )  
**UK** +44 20 8068 2023 (9am-6pm, GMT, Mon-Sat)  
**DE** +49 32221097297 (11am-9pm, CET, Mon-Sat )  
**FR** + 33 176340312 (11am-9pm, CET, Mon-Sat )  
**IT** +39 06 9480 3330 (9am-6pm, CET, Mon-Sat )  
**ES** + 34 931786261 (9am-6pm, CET, Mon-Sat )  
**AU** + 61 2 8310 9897 (11am-7pm, AEST, Mon-Fri)

---

 **FAQ** [avantree.com/support/aria-pro-2](https://avantree.com/support/aria-pro-2)

---

 **Product Registration** [avantree.com/product-registration](https://avantree.com/product-registration)

# Índice de contenidos

Contenidos del Paquete .....	63
Introducción del Producto .....	64
Descripción del Producto .....	64
Función de las Teclas .....	65
Indicadores LED.....	66
Recarga los Auriculares .....	67
Conexión de los Auriculares al Dispositivo .....	68
Emparejamiento y conexión .....	68
Configuración de Ajustes de Audio (solo para PC) .....	70
Llamada con Micrófono Externo .....	72
Especificaciones .....	73
FAQ .....	74
Contáctenos .....	76



# Contenidos del Paquete

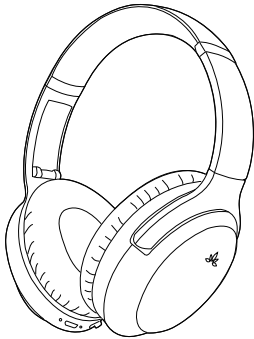

Auriculares Aria Pro 2

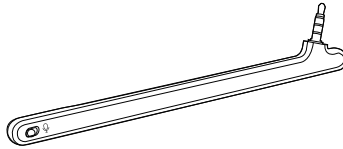

Micrófono Externo

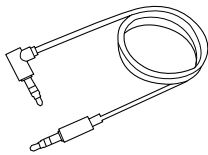

Cable Audio  
AUX 3.5mm

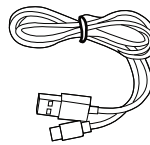

Cable de Carga  
Type C







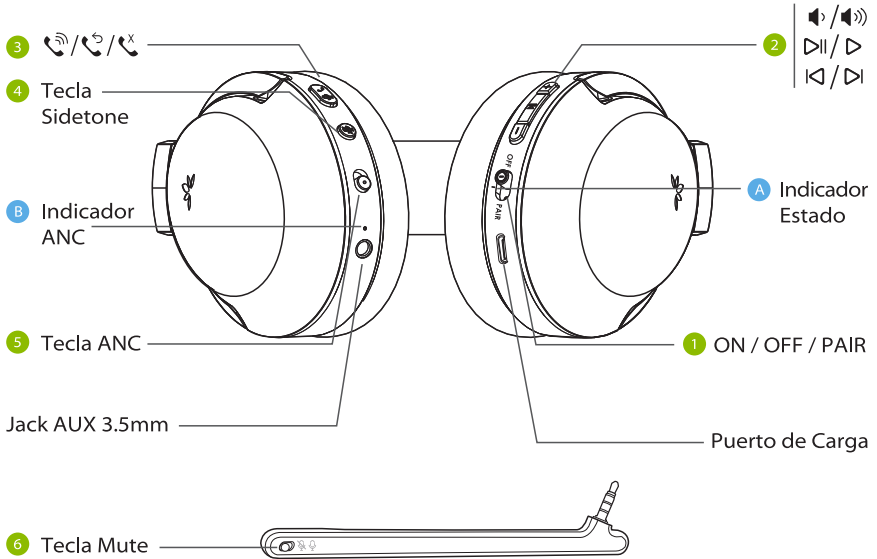

# Introducción del Producto

## Descripción del Producto

ES



## Función de las Teclas

No.	Tecla	Funcion
1		Cambiar a la posición "ON/OFF" para encender/apagar los auriculares.
		Poner a la posición "PAIR" y manténgalo presionado durante 3 segundos para ingresar al modo de emparejamiento
2		Presione una vez para reproducir/pausar
		Presione una vez para aumentar/disminuir el volumen
		Mantenga presionado durante 2 segundos para saltar/reproducir la canción
3		Mantenga presionados ambos botones durante 5 segundos para borrar el historial de emparejamiento
		Presione una vez para aceptar/finalizar la llamada
		Mantenga presionado durante 2 segundos para rechazar la llamada
4		Presione dos veces para volver a marcar el último número
		Durante una llamada, mantenga presionado durante 3 segundos para alternar el tono lateral (monitoreo del micrófono)
5		Presionar para activar/desactivar la cancelación activa de ruido
6		Poner en  /  para activar/desactivar el micrófono
2 4		Mantenga presionado "Sidetone & +" o "Sidetone & -" durante 1 segundo para activar/desactivar las alertas de voz

## Indicadores LED

No.	Indicador y Alerta de Voz	Estado
A	Rojo fijo	En charge
	Parpadeo en rojo, mensaje de voz "LOW BATTERY"	Bateria baja
	Azul intermitente cada 2 segundos, mensaje de voz "WELCOME TO AVANTALK"	Encendido
	Rojo fijo durante 1 segundo y luego apagado, mensaje de voz "GOODBYE"	Apagado
	Parpadeos rojos y azules alternados, mensaje de voz "PAIRING".	Emparejamiento
	Parpadeo azul cada 5 segundos, mensaje de voz "CONNECTED".	Conectado
	Parpadeo azul cada 2 segundos, mensaje de voz "DISCONNECTED".	Desconectado
	Rosa fijo durante 5 segundos, luego se alternan destellos rojos y azules	Historial de conexiones eliminado
	Blanco fijo durante 5 segundos, dos pitidos	Sidetone encendido / apagado
B	Verde fijo, mensaje de voz "NOISE CANCELING"	Modo de Cancelación de Ruido (ANC)

## Recarga los Auriculares

Un mensaje de voz "LOW BATTERY" y una luz roja parpadeante indicarán que la batería está baja. Para cargar los auriculares, puede utilizar un adaptador USB de 5 V/500 mA-2 A como fuente de alimentación (el cargador del teléfono o similar debería funcionar) o el puerto USB de su PC.

Enchufe el cable de alimentación tipo C incluido directamente en el puerto de carga de los auriculares.

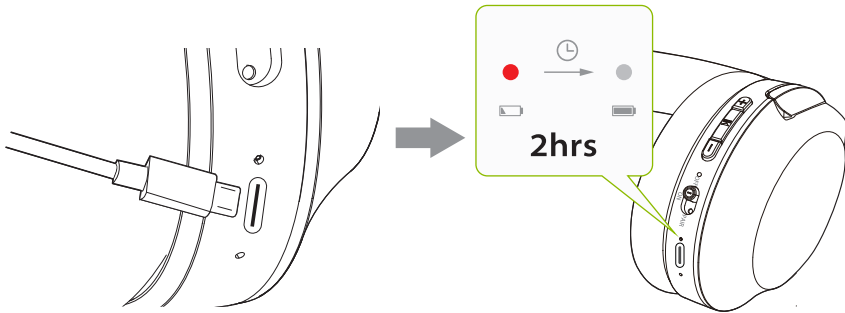

Una luz roja fija indica que la carga está en curso; una vez que la luz se apaga, sus auriculares estarán completamente cargados.

# Conexión de los Auriculares al Dispositivo

## Emparejamiento y conexión

### PASO 1

Enciende los auriculares y ponlos en modo PAIRING deslizando la tecla  a "PAIR" y manténgala presionada durante 3 segundos o hasta que el LED parpadee en rojo y azul.

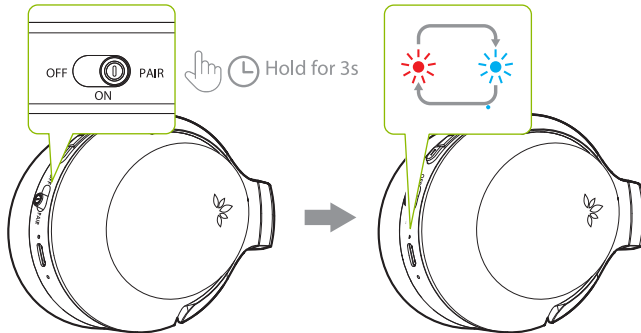



### PASO 2

Active el Bluetooth de su dispositivo y seleccione "Avantalk Aria Pro 2" en el menú de Bluetooth.

### PASO 3

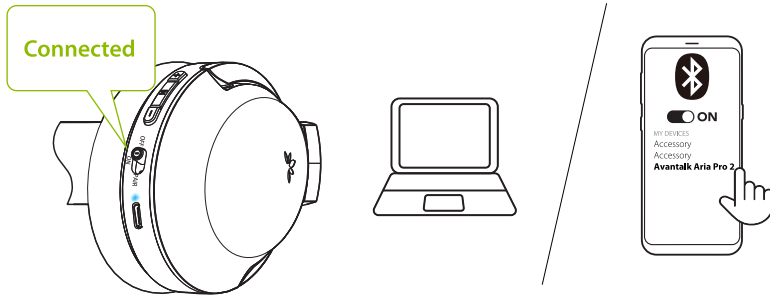
Mantenga los auriculares cerca de su dispositivo y espere de 5 a 10 segundos o hasta que se conecten. Una vez conectado con éxito, escuchará un indicador de voz "CONECTADO" en los auriculares. El indicador LED de los auriculares parpadeará en azul, luego se volverá azul fijo una vez que se esté reproduciendo el audio.



Para un uso posterior, los auriculares deberían volver a conectarse automáticamente al último dispositivo emparejado unos segundos después de encenderlos. De lo contrario, puede activar manualmente la reconexión deslizando la tecla  en "PAIR" una vez, o seleccionando "Avantalk Aria Pro 2" en el menú Bluetooth de su dispositivo.

## Configuración de Ajustes de Audio (solo para PC)

Es posible que deba configurar los ajustes de audio cuando utilice el Aria Pro 2 con su PC o computadora portátil.

### PASO 1

Accede a la configuración de audio de tu dispositivo y establece "Avantalk Aria Pro 2" como predeterminado en SALIDA DE AUDIO / REPRODUCCIÓN. Configure "Avantalk Aria Pro 2" como predeterminado en DISPOSITIVO DE ENTRADA/MICROFONO.

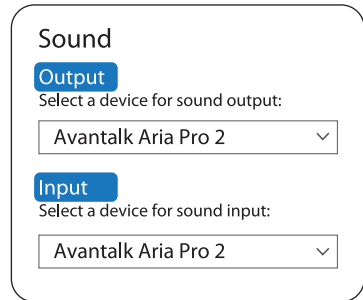
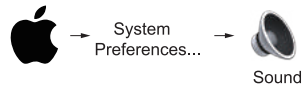
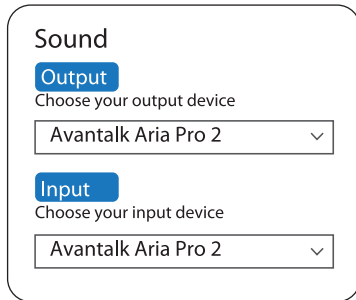
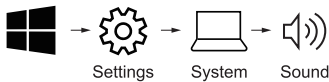



**PASO 2**

Repita los pasos anteriores en su software de reuniones (Teams, Zoom, Skype, etc.).

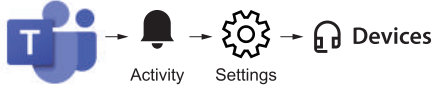

Activity → Settings → Devices

**Audio devices**

Avantalk Aria Pro2 ▾

**Speaker**

Avantalk Aria Pro2 (Hands Free) ▾

**Microphone**

Avantalk Aria Pro2 (Hands Free) ▾



Settings → Audio

**Speaker** Test Speaker Avantalk Aria Pro2 (Hands Free) ⌵

**Microphone** Test Mic Avantalk Aria Pro2 (Hands Free) ⌵



Settings → VOICE SETTINGS

INPUT DEVICE: Avantalk Aria Pro2 (Hands Free) ▾

OUTPUT DEVICE: Avantalk Aria Pro2 (Hands Free) ▾

INPUT VOLUME: [Slider]

OUTPUT VOLUME: [Slider]

*NOTA: En Windows 11 / macOS, la opción "Altavoz" no está disponible; seleccione "Avantalk Aria Pro 2" como el valor predeterminado en su lugar.*

## Llamada con Micrófono Externo

Los auriculares Aria Pro 2 tienen un micrófono incorporado, pero usar el micrófono externo mejorará significativamente la calidad de las llamadas. Su tecnología de filtrado de ruido garantizará que su voz (y solo su voz) se escuche alto y claro, y su interruptor de silencio se puede operar convenientemente.

# Especificaciones

## Auriculares

Versión Bluetooth	v5.0
Codecs de audio compatibles	aptX-HD, aptX-LL, aptX, SBC
Perfiles compatibles	HSP v1.2, HFP v1.7, AVRCP v1.6, A2DP v1.3.1
Rango de alcance	Hasta a 30ft / 10m
Drivers	40mm
Impedancia	32Ω
Frecuencia de respuesta	20Hz - 20KHz
Tiempo de carga	~2 horas
Tiempo de uso	Hasta a 24 horas (ANC desactivado)
Tiempo de standby	325 horas (ANC desactivado)
Medidas	190mm x 175mm x 80mm
Peso de los auriculares	~230g
Diámetro interior de los auriculares	60mm x 40mm x 35mm
Diámetro exterior de los auriculares	101mm x 80mm
Input	DC5V/500mA~2.0A
Puerto de carga	Type C

## FAQ

A continuación se presentan algunas de las preguntas más comunes que la gente tiene al instalar su producto.

### **Por qué el micrófono no funciona en la PC?**

Hay varias razones por las que el micrófono puede no funcionar con su PC. Primero, verifique su micrófono externo para asegurarse de que el interruptor de silencio esté apagado. El problema también podría estar relacionado con el hardware o la configuración de su computadora. Para determinar si se trata de un problema de hardware, conecte los auriculares a su teléfono e intente llamar a alguien, con y sin el micrófono boom. Si no hay problemas, vuelva a verificar la configuración de su computadora.

- Asegúrese de que solo una aplicación de reunión esté abierta a la vez.
- Asegúrese de que la configuración de su PC sea correcta: verifique la configuración de audio de su computadora y asegúrese de que Aria Pro 2 esté seleccionado como dispositivo de entrada y salida de audio. Compruebe también la configuración de audio de su software de reuniones.
- Asegúrese de que no haya interferencias de un segundo dispositivo: si Aria Pro 2 está conectado a otro dispositivo a través de un enlace dual al mismo tiempo, intente desconectarse del otro dispositivo.

### **Escucho el micrófono reproduciendo sonidos ambientales durante una llamada; Por qué pasó esto? Las personas al otro lado de la llamada también lo sienten?**

Si tiene activada la función sidetone (que le permite escuchar su propia voz), a veces se captará ruido a su alrededor y es posible que lo escuche durante la reproducción. Los demás participantes de la llamada NO lo escucharán si usa el micrófono con filtro de ruido. Puede intentar acercarse al micrófono externo a su boca para reducir la cantidad de ruido ambiental transmitido a través del tono local, o puede apagar el tono local manteniendo presionado el botón "tono local" durante 3 segundos durante una llamada, si lo prefiere.

## **La luz indicadora de mis auriculares de repente se puso roja y ahora los botones no funcionan. Qué tengo que hacer?**

Puede restablecer los auriculares conectando el cable de carga en el puerto de carga de los auriculares y conectando el otro extremo a una fuente de alimentación durante 3 a 5 segundos. Esto debería reactivar el sistema de auriculares y solucionar el problema. De lo contrario, puede contactarnos en [support@avantalk.com](mailto:support@avantalk.com) y podemos ayudarlo directamente.

Puede encontrar una lista completa de preguntas frecuentes en [avantree.com/support/aria-pro-2](https://avantree.com/support/aria-pro-2) o contáctenos directamente para obtener más ayuda.

## Contáctenos

**Support Tickets**[avantree.com/submit-a-ticket](https://avantree.com/submit-a-ticket)**Support Email**[support@avantalk.com](mailto:support@avantalk.com)**USA / CA**

+1800 232 2078 (9am-6pm PST, Mon-Fri)

**UK**

+44 20 8068 2023 (9am-6pm, GMT, Mon-Sat)

**DE**

+49 32221097297 (11am-9pm, CET, Mon-Sat)

**FR**

+ 33 176340312 (11am-9pm, CET, Mon-Sat)

**IT**

+39 06 9480 3330 (9am-6pm, CET, Mon-Sat)

**ES**

+ 34 931786261 (9am-6pm, CET, Mon-Sat)

**AU**

+ 61 2 8310 9897 (11am-7pm, AEST, Mon-Fri)

**FAQ**[avantree.com/support/aria-pro-2](https://avantree.com/support/aria-pro-2)**Product Registration**[avantree.com/product-registration](https://avantree.com/product-registration)

Manufacturer: Avantronics Limited

Address: Luohu District, Shenzhen 518000 China

US Importer:

Avantree Corporation

San Jose, California 95119 USA

UK Importer:

Avantree Limited

Watford, WD180 0HQ UK



Servicer in Europe:

Gizmex GmbH,

Sternstr. 67, 40479 Dusseldorf, Germany

Tel: 01 – 408 334 8648 support@avantree.com



Model No:ATBH-AS90P  
Dispose of the packaging and this product in accordance with the latest provisions.  
Z-PKQG-AS90P-ENC-V4